

## Product Bulletin

# WLAN Solutions: TNETW1130 Converged Single-Chip MAC and Baseband Processor for IEEE 802.11 a/b/g



The single-chip TNETW1130 media access controller/baseband processor for wireless local area networks (WLAN) is a complete and converged solution supporting full 54 megabits per second (Mbps) data transfer speeds and all 802.11 WLAN standards and draft standards. The device features seamless operation in the 2.4-GHz and 5.2-GHz bands and is fully compatible with the installed base of client and access point (AP) WLAN equipment.

TI's TNETW1130 offers compatibility with the WLAN standards for 802.11a, 802.11b and 802.11g draft standards. The device is software upgradeable to be fully compliant with the 802.11g standard once the draft specification has been approved as a full standard. In addition, the TNETW1130 supports the recent refinements to the WLAN standard, addressing issues such as security- supporting both Wi-Fi Protected Access (WPA) as well

as the 802.11i draft standard; Quality of Service (QoS) supporting the 802.11e draft standard; and global 802.11a deployment-supporting the 802.11h draft standard.

The TNETW1130 is one of the first WLAN MAC/baseband processors to fulfill the requirements of the 802.11 security and privacy draft standard, 802.11i. The TNETW1130 supports Advanced Encryption Standard (AES) plus legacy support for WEP (Wired Equivalency Protocol). As 802.11i mandates, the TNETW1130 has hardware accelerators for WPA and the mandatory and optional implementations of AES. Further security enhancements include support for LEAP 802.1x authentication type and additional forthcoming enhancements for an additional level of WLAN security.

The TNETW1130 also has a QoS engine for support of enhanced distributed coordination function (EDCF) and hybrid coordination function (HCF) as specified in the 802.11e draft standard. This allows a WLAN to dedicate bandwidth for emerging real-time applications like voice-over-WLAN, broadcast video, video conferencing and others. Additionally, the device incorporates transmit power control (TPC), dynamic frequency selection (DFS) and other

### Key Features

- True dual-band 54 megabits per second (Mbps) data in the 2.4-GHz and 5.2-GHz U-NII bands
- Hardware-accelerated Advanced Encryption Standard (AES) for mandatory (AES-CCMP)
- Wi-Fi® Compliant 802.11g operation
- Compatible with all versions and additions to the 802.11 standard: 802.11a, 802.11b, 802.11g, 802.11e draft, 802.11h and 802.11i draft
- Field-programmable architecture that supports standard changes
- Seamless interoperability and automatic fallback operation in the 2.4-GHz band between the higher-speed 802.11g and established 802.11b modes
- Auto-Band™ feature automatically selects between the 5.2-GHz and the 2.4-GHz bands and modulations, based on user profile configurations
- ELP™ — Optimized low power consumption for maximum battery life
- Optional 802.11g+ mode provides 50% greater throughput over competitive 802.11g solutions

capabilities that are specified in 802.11h that are critical for worldwide deployment of WLAN clients and APs.

To facilitate transparent operations, the TNETW1130 is capable of seamless and dynamic transition between the established WLAN standards for 802.11a and 802.11b and the newer, high-speed version of 802.11 in the 2.4GHz band, the draft standard 802.11g. Drawing on TI's market-proven experience with multi-modulation WLAN technology, the TNETW1130 and the accompanying system reference designs will be able to automatically switch between the different transmission modes and frequency bands, seamlessly supporting CCK, PBCC™ and now OFDM.

Using Auto-Band™ technology, TNETW1130-based access points (APs) can simultaneously operate, and stations can automatically switch between the different transmission modes and frequency bands, seamlessly supporting 802.11b, 802.11b+, 802.11g, or 802.11a. The TNETW1130 will enable TI customers to offer the first true multimode products.

For high bandwidth multimedia services such as video, shared gaming, audio and voice, the

TNETW1130 offers an optional 802.11g+ performance increase. In this mode, TNETW1130-based devices offer an increase in throughput of up to 50%.

Reference designs based on the TNETW1130 come in multiple modes and form factors to meet the needs of different markets, including 802.11g PC Cards and APs for home/SOHO networking kits, 802.11a/g PC Cards for enterprise applications, and 802.11a/g mini-PCI cards for PC OEMs. The TNETW1130 can be implemented in a diverse set of client and AP applications through a broad host of interfaces needed for 802.11 station and AP applications. These include PCMCIA, Cardbus, PCI, Mini-PCI, USB, Compact Flash and 16-bit generic slave.

### High-Performance RF and Low Power Consumption

For dual-band 2.4-GHz and 4.9 to 5.9-GHz operations supporting 802.11b, 802.11g and 802.11a, the TNETW1130 utilizes a high-performance single-chip radio frequency (RF) solution that includes an external power

amplifier (PA). This RF solution is well suited to low-cost, high-yield manufacturing applications.

Like TI's ACX100 and TNETW1100B, the TNETW1130 offers higher throughput at longer distances for 802.11b, 802.11b+ (22Mbps), 802.11g, 802.11g+ and 802.11a networks leveraging TI's multipath and receiver technology. For battery-operated and mobile WLAN applications, the TNETW1130 has been optimized for low power consumption by taking advantage of the numerous innovations TI has pioneered in 802.11 standby power modes. With these breakthrough power saving features, TI provides substantial power savings compared to existing solutions.

The TNETW1130 is packaged in a space-saving 16 x 16 mm 257-pin ball grid array (BGA) package, which is pin-for-pin compatible with TI's previous generation WLAN MAC/baseband processor device.

### For More Information

For more information, please visit: [www.ti.com/wlan](http://www.ti.com/wlan)

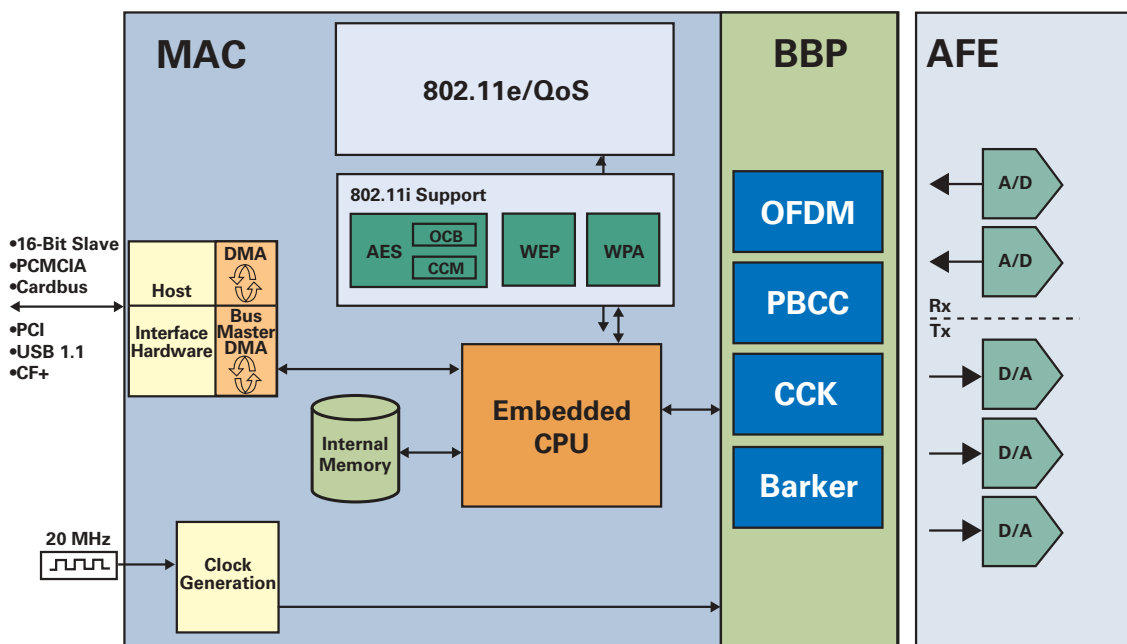

TNETW1130 (ACX111)

## TNETW1130

### Extensive Hardware and Software Features

Features	Benefits
<ul style="list-style-type: none"><li>• Embedded ARM CPU</li></ul>	<ul style="list-style-type: none"><li>• Powerful processing to maintain high throughput rates.</li></ul>
<ul style="list-style-type: none"><li>• 32-bit Cardbus, generic 16-bit, PCI, MiniPCI, USB1.1, and CF+ host interfaces</li></ul>	<ul style="list-style-type: none"><li>• Ability to choose form factors to fit application.</li></ul>
<ul style="list-style-type: none"><li>• Supports bus mastering in Cardbus/PCI modes</li></ul>	<ul style="list-style-type: none"><li>• Allows fast data movement out of the adapter and enables a single-chip solution.</li></ul>
<ul style="list-style-type: none"><li>• No external RAM/Flash required</li></ul>	<ul style="list-style-type: none"><li>• 128 KB of embedded RAM meets memory needs and results in a lower system BOM.</li></ul>
<ul style="list-style-type: none"><li>• DMA allows data in host memory to be stored in non-contiguous memory buffers</li></ul>	<ul style="list-style-type: none"><li>• Reduces number of copy operations that the host must perform, resulting in more bandwidth for other tasks.</li></ul>
<ul style="list-style-type: none"><li>• Antenna diversity actively selects the best antenna for greatest signal strength</li></ul>	<ul style="list-style-type: none"><li>• Improves throughput by minimizing retransmission.</li></ul>
<ul style="list-style-type: none"><li>• Supports WPA (SSN), TKIP, AES (CCM)</li></ul>	<ul style="list-style-type: none"><li>• Complete support of 802.11i draft standard to provide high level of security and add more effective authentication methods.</li></ul>
<ul style="list-style-type: none"><li>• Supports Quality of Service (QoS) applications</li></ul>	<ul style="list-style-type: none"><li>• Complete support of 802.11e draft standard that provides support for real-time applications with fixed bandwidth and timing requirements.</li></ul>
<ul style="list-style-type: none"><li>• Supports Transmit Power Control (TPC) and Dynamic Frequency Selection (DFS)</li></ul>	<ul style="list-style-type: none"><li>• Complete support of 802.11 h draft standard that provides support for global certification.</li></ul>
<ul style="list-style-type: none"><li>• Optimized power consumption</li></ul>	<ul style="list-style-type: none"><li>• Provides lowest power consumption to maximize battery life for mobile devices.</li></ul>
<ul style="list-style-type: none"><li>• Support for infrastructure and ad-hoc modes</li></ul>	<ul style="list-style-type: none"><li>• Easy to configure for multiple network structures.</li></ul>
<b>Comprehensive Development Packages</b>	
<ul style="list-style-type: none"><li>• Hardware Development Kits (including schematics, layout, Gerber files and radio control utility software)</li></ul>	<ul style="list-style-type: none"><li>• Hardware development time is minimized with TI's complete, proven form factor reference designs.</li></ul>
<ul style="list-style-type: none"><li>• Driver Development Kits</li></ul>	<ul style="list-style-type: none"><li>• Complete turnkey NDIS and Windows®CE drivers expediting time-to-market.</li></ul>
<ul style="list-style-type: none"><li>• Configuration Utility Development Kit</li></ul>	<ul style="list-style-type: none"><li>• Complete customizable software kit for a configuration application.</li></ul>
<ul style="list-style-type: none"><li>• Manufacturing and Test Software Kit</li></ul>	<ul style="list-style-type: none"><li>• Software library and sample program for all supported form factors applications allows for direct integration into volume manufacturing test program.</li></ul>
<ul style="list-style-type: none"><li>• Access Point Development Kit</li></ul>	<ul style="list-style-type: none"><li>• Enables rapid access point driver development.</li></ul>
<b>Standards Compliance</b>	
<ul style="list-style-type: none"><li>• TI system test facility</li></ul>	<ul style="list-style-type: none"><li>• Provides in house test using FCC, Wi-Fi and WHQL test suites as well as TI designed performance test suites.</li></ul>
<ul style="list-style-type: none"><li>• Ready for Wi-Fi testing</li></ul>	<ul style="list-style-type: none"><li>• Intended for Wi-Fi compliant applications.</li></ul>
<ul style="list-style-type: none"><li>• Drivers approved by WHQL</li></ul>	<ul style="list-style-type: none"><li>• Products based on the complete TI WLAN reference design are WHQL-approved.</li></ul>
<ul style="list-style-type: none"><li>• Stamped with the Windows® XP logo</li></ul>	<ul style="list-style-type: none"><li>• Windows XP supports 802.11, and TI WLAN reference design-based products can bear the "Designed for Microsoft® Windows® XP" logo.</li></ul>

**Important Notice:** The products and services of Texas Instruments Incorporated and its subsidiaries described herein are sold subject to TI's standard terms and conditions of sale. Customers are advised to obtain the most current and complete information about TI products and services before placing orders. TI assumes no liability for applications assistance, customer's applications or product designs, software performance, or infringement of patents. The publication of information regarding any other company's products or services does not constitute TI's approval, warranty or endorsement thereof.

Real World Signal Processing, the black/red banner, Auto-Band, ELP and PBCC are trademarks of Texas Instruments Incorporated.  
All other trademarks are the property of their respective owners.